

## ▶ | MarSurf. Surface Measurement

<b>Mobile Roughness Measuring Devices</b>	<b>4</b>
<b>Perthometer M1</b>	<b>5</b>
<b>Perthometer M2</b>	<b>6</b>
<b>Mobile Roughness Measurement. Technical Data</b>	<b>7</b>
<b>Workstation MarSurf XR 20 for M-units</b>	<b>8</b>
<b>Application Aides</b>	<b>9</b>
<b>Pick-ups for Mobile Roughness Measuring Instruments</b>	<b>12</b>
<b>Drive Units for Mobile Roughness Measuring Instruments</b>	<b>14</b>
<b>Application with PFM Drive Units</b>	<b>15</b>
<b>Accessories</b>	
<b>Mechanical Accessories</b>	<b>16</b>
<b>Measuring Stands</b>	<b>17</b>
<b>Perthometer Sets for Mobile Operation</b>	<b>18</b>



아이에스테크 ::: INTERNAL STANDARD TECHNOLOGY :::

주소: 경기도 성남시 분당구 아탑3동 306-5번지 102호 우: 463-856

Http:// [www.is77.co.kr](http://www.is77.co.kr)

Tel: 82-31-704-2401

Fax: 82-31-704-2421

E-mail: [is@is77.co.kr](mailto:is@is77.co.kr)

## MarSurf. Handy and precise for on-site roughness measurements

### MOBILE ROUGHNESS MEASUREMENT DEVICES

▶ | Mahr has played a key role in ensuring the success of mobile roughness measurement devices. As early as the 1980s, Mahr was setting new standards with the M4P. The products have developed in line with changing production monitoring requirements. Today's devices meet the highest international standards. Mobile roughness measurement devices from Mahr are light-weight with a handy shape, flexible handling, high-precision measurement in different positions and easy positioning using V-blocks.



## Perthometer M1. The Basic Model for Roughness Measurements

Entry-level roughness measurement



### Description

This instrument serves for determining and documenting the most common parameters as per DIN EN ISO/AMSE/prEN 10049 (Ra, Rz, Rmax, and RPC) and according to the JIS Japanese standard (Rz, Ra).

With a minimum of keys, the Perthometer M1 is characterized by a multitude of functions. An automatic function enables periodic and aperiodic profiles to be identified and the cutoff to be set according to standards without any previous test measurement, such that unintentional non-standard measurements are excluded.

In mobile use, the measuring record can be output on the built-in thermal printer automatically or simply by pressing a key. Stationary operation offers the possibility of connecting the Perthometer directly to a PC via the serial interface.

Delivery as a set in a handy carrying case,  
Perthometer M1 set  
Perthometer M1 set with 2008143 patch

**Order No. 6910134**

**Order No. 2190827**

### Features

- Measuring range of up to 150  $\mu\text{m}$  (6,000  $\mu\text{in}$ )
- Units  $\mu\text{m}/\mu\text{in}$  selectable
- Standards: DIN/ISO/JIS
- Traversing lengths 1.75 mm, 5.6 mm, 175 mm (.7 in, .22 in, 0.7 in)
- Cutoff 0.25 mm/0.80 mm/2.5 mm (.010 in/.032 in/.100 in)
- Short cutoff selectable
- Number of sampling lengths selectable from 1 to 5
- Automatic selection of filter and traversing length conforming to standards
- Phase-correct profile filter as per DIN EN ISO 11562
- Parameters as per DIN/ISO/SEP: Ra, Rz, Rmax, RPC and JIS: Ra, Rz
- Automatic scaling according to the profile amplitude
- Printing of roughness profile and measuring record
- Dynamic pick-up calibration
- Blocking of instrument settings for preventing unintentional modifications

## Perthometer M2. The Universal Standard Instrument ...

Highly mobile, high-performance unit



### Description

The operation of this instrument is based on the well-proved catalog of functions which enables instrument settings such as measuring conditions, language and record contents to be selected very easily. The **Perthometer M2** thus offers a maximum of comfort and flexibility.

Compared with the **Perthometer M1**, this instrument not only meets the requirements for determination and documentation of selected parameters, but also makes most of the parameters and characteristic curves stipulated in DIN/ISO/JIS available for the evaluation of the profile assessed.

Moreover, the **Perthometer M2** offers an integrated memory for the results of up to 200 measurements and enables, among other things, tolerance monitoring, vertical scale selection and the setting of unsymmetric intersection lines for peak count calculation.

Delivery as a set in a handy carrying case,  
Perthometer M2 set  
Perthometer M2 set with 2008143 patch

**Order No. 6910135**

**Order No. 2190828**

### Features

- Measuring range of up to 150  $\mu\text{m}$  (6000  $\mu\text{in}$ )
- Units  $\mu\text{m}/\mu\text{in}$  selectable
- Standards: DIN/ISO/JIS and CNOMO (Motif) selectable
- Traversing lengths as per DIN EN ISO 4288/ASME B461: 1.75 mm, 5.6 mm, 17.5 mm (.07 in, .22 in, .7 in); as per EN ISO 12085: 1 mm, 2 mm, 4 mm, 8 mm, 12 mm, 16 mm
- Number of sampling lengths selectable from 1 to 5
- Automatic selection of filter and traversing length conforming to standards
- Phase-correct profile filter as per DIN EN ISO 11562
- Cutoff 0.25 mm/0.80 mm/2.50 mm (.010 in/.032 in/.100 in)
- Short cutoff selectable
- Parameters as per DIN/ISO/SEP:  $R_a$ ,  $R_z$ ,  $R_{max}$ ,  $R_p$ ,  $R_q$ ,  $R_t$ ,  $R_{3z}$ ,  $R_k$ ,  $R_{vk}$ ,  $R_{pk}$ ,  $Mr_1$ ,  $Mr_2$ ,  $Mr$ ,  $Sm$ ,  $RPC$ ; as per JIS:  $R_a$ ,  $R_z$ ,  $R_y$ ,  $Sm$ ,  $S$ ,  $tp$ ; Motif parameters:  $R$ ,  $R_x$ ,  $Ar$ ,  $W$ ,  $CR$ ,  $CF$ ,  $CL$  (three-zone measurement)
- Tolerance monitoring in display and measuring record
- Automatic or adjustable scaling
- Printing of R-profile (ISO/JIS), P-profile (MOTIF), material ratio curve, measuring record
- Output of date and/or time of the measurements
- Integrated memory for the results of up to 200 measurements
- Dynamic pick-up calibration
- Blocking of instrument settings for preventing unintentional modifications plus possibility of password protection

## Mobile Roughness Measurements. Technical Data

	M1	M2
Measuring principle	stylus method	•
Traversing speed	0.5 mm/s	•
Measuring ranges	100 μm (4,000 μin) 150 μm (6,000 μin)	• •
Profile resolution	12 nm	•
Filter	Gaussian	•
Cutoffs	0.25/0.8/2.5 mm (0.010/0.032/0.100 in)	0.25/0.8/2.5 mm (0.010/0.032/0.100 in)
Short cutoff	•	•
Traversing lengths as per DIN/ISO	1.75/5.6/17.5* mm (0.07/0.22/0.70* in)	1.75/5.6/17.5* mm (0.07/0.22/0.70* in)
as per EN ISO 12085	1/2/4/8*/12*/16* mm	1/2/4/8*/12*/16* mm
Evaluation lengths	1.25/4/12.5* mm (0.05/0.16/0.5* in)	1.25/4/12.5* mm (0.05/0.16/0.5* in)
Number of sampling lengths	selectable from 1 to 5	•
Standards	DIN/ISO/JIS/ASME	DIN/ISO/JIS/ASME
Parameters	DIN/ISO/ASME: Ra, Rz, Rmax, RPc JIS: Ra, Rz	DIN/ISO/ASME: Ra, Rz, Rmax, Rp, Rq, Rt, R3z, Rk, Rvk, Rpk, Mr1, Mr2, RPc, Mr, RSm. JIS: Ra, Rz, Ry, Sm, S, tp MOTIF: R, Ar, Rx, W, CR, CL, CF
Vertical scale	automatic	automatic/selectable
Horizontal scale	dep. on cutoff	dep. on cutoff
Record contents	R-profile, results	R-profile, MRC, P-profile (MOTIF), results
Printing	automatic/manual	automatic/manual record with time
Calibration function	dynamic (Rz value)	•
Memory	–	integrated memory for results of up to 200 measurements
Units μm/μinch	selectable	selectable
Languages	selectable: English, German, French, Italian, Spanish, Portuguese., Dutch, Swedish, Czech, Polish, Russian, Japanese, Chinese, Korean	•
Russ., Pol., Czech., Jap.,	•	•
Blocking for instrum. settings	–	•
Password protection	•	•
Membrane keypad		
LCD	purposefully designed with graphics area	
Printer	thermal printer, 384 points/horizontal line, 20 characters/line	
Printing speed	approx. 6 lines/second corresponds to approx. 25 mm/s (1 in/s)	
Thermal paper	dia. 40.0 mm - 1.0 mm (1.575 in - .0394 in), width 57.5 mm ± 0.5 mm (2.263 in ± .0197 in), externally coated RS 232 C	•
Interface	NiMH battery, capacity: approx. 1,000 measurements (dep. on number and length of record printouts), plug-in power pack with three mains plugs, for input voltages from 90 V to 264 V	•
Power supply	•	•
Power management	•	•
Connections	drive unit, RS 232 C, power pack	•
System of protection	IP 50	•
Temperature range for		
– storage	–15 °C to +55 °C (5 °F to 131 °F)	•
– operation	+5 °C to +40 °C (41 °F to 104 °F)	•
Relative humidity	30 % to 85 %	•
Dimensions (L x W x H)	190 mm x 170 mm x 75 mm (7.48 in x 6.69 in x 2.95 in)	• •
Mass	approx. 900 g (1.984 lb)	•

\* only with PFM drive unit

## Workstation MarSurf XR 20 for M-units

Archiving and documenting made easy



### Description

The **MarSurf XR 20** workstation is based on the PC measuring system software. The software enables the measuring result to be archived and documented very easily. Here, the **M**-unit is controlled by a PC, i.e. the measuring conditions are set on the PC or laptop.

Clear icons and a comprehensive online help make using this powerful software very easy. Decades of surface metrology experience in are combined with state-of-the-art and future-focused technologies.

The workstation supports WINDOWS 2000 and WINDOWS XP. Data transmission is performed via an RS 232 cable between M-unit and PC. For accessing the software, a USB dongle and a license file are required.

### Features

- Over 65 parameters may be selected for R, P and W profiles as per ISO / JIS or MOTIF
- Tolerance monitoring and statistics for all parameters
- Fast creation of Quick & Easy measuring programs using Teach-In mode
- Comprehensive logging
- Simulation mode to help users familiarize themselves with the system quickly
- Numerous measuring station configurations for customized applications
- Different user levels can be set up
- Printout of an A4 form via a PC printer
- Archiving of the measured profiles on PC or laptop

### Accessories

- Software MarSurf XR 20
- USB dongle
- Floppy disk 3,5" with license file
- RS 232 cable (2 m)

**Order no. 6299009**

## Application Aids

Efficient application aids for manufacturing

### MarSurf BF-1



### MarSurf TF-1



### MarSurf DR-1

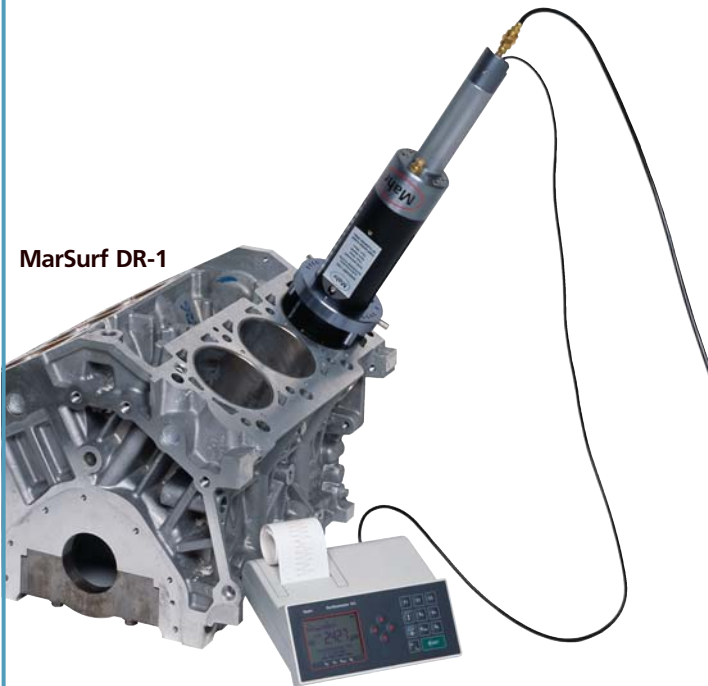

### MarSurf CB-2



## Description

Tough manufacturing environments require quick and easy roughness measurement. The shop floor is particularly demanding on measuring instruments. **Application aids** from **Mahr** are the perfect solution

## Features

Our application aids work with evaluation instruments in the **M1** or **M2 series**.

A calibration or storage station is included in the scope of delivery. Calibration standards are available, with a Calibration Certificate if required.

- Special design allows precise, easy positioning of measuring instrument
- Easy to use even without specialist metrological knowledge
- Device for protecting drive unit from environmental influences that might disrupt the measurement
- Pick-up protection, i.e. pick-up is only extended during measurement
- Surface protection material ensures measurement leaves no marks on the workpiece

## Applications

### Engine blocks:

- Crankshaft bore sensor hole
- Dipstick hole
- Crankshaft bores (1st and last journal only)
- Water pump bore
- Freeze plug bore

### Crankshafts:

- Pilot bore on the end of crankshaft

### Connecting rods:

- Pin bores
- Crank bores

### Cylinder heads:

- Camshaft bores (1<sup>st</sup> and last journal only)

## MarSurf BF-1

Miscellaneous bore fixtures for the shop floor



### Description

The **MarSurf BF-1** is designed for measurements on the shop floor. The centring device adapted to the specific measuring task enables the pick-up to be positioned directly to the measuring position.

### Features

- Tooling can be designed to measure openings from 12.7 mm to 150 mm
- Adjustable measuring depth of 10 mm through 75 mm
- Automatic pick-up protection means the pick-up is only exposed during the measuring cycle
- Calibration stand included in the scope of delivery
- The fixture can be used with M1 or M2 units

### Accessories

- The tooling is always order-related, i.e. designed for a special measuring task
- Optional: The **MarSurf BF-1** can also be supplied without adjustable measuring depth, i.e. it is designed for just one measuring task

## MarSurf TF-1

Crankshaft thrust face measurement fixture



### Description

The **MarSurf TF-1** is designed for measurements in the shop floor, i.e. for measuring crankshaft thrust faces. The special design enables easy handling, i.e. the pick-up automatically positioned to the measuring position.

### Features

- Tooling can be designed to measure crankshafts from 17.5 mm to 44.5 mm
- Non marring material leaves no traces on the workpiece
- Automatic pick-up protection means the pick-up is only exposed during the measuring cycle
- Calibration stand included in the scope of delivery
- The fixture can be used with M1 or M2 units



## MarSurf CB-2

Cylinder bore surface finish fixture



### Description

The **MarSurf CB-2** is designed for the measurement of cylinder walls, sleeves or any bores requiring surface roughness measurements. High clamping force supported by air pressure for stable measurements inside bores from 77 mm through 106 mm.

### Features

- Auto sizing feature for bores from 77 mm through 106 mm
- Mechanical stop with depth indicator
- Automatic probe protection means the pick-up is only exposed during the measurement cycle
- MarSurf CB-2 utilizes a pneumatically activated damping mechanism
- Measurement depth capability of 25 mm through 225 mm
- The fixture can be used with M1 or M2 units

### Accessories

- **MarSurf CB-2 bore fixture**      **Order No. 2190856**  
(for bores from 77 mm through 81 mm), including air connection hose 3.65 m and bore expansion plate for bores ranging from 81 mm through 89 mm, from 89 mm through 87 mm and from 97 mm through 106 mm in diameter
- The system require a shop floor air pressure of 0.45 N/mm<sup>2</sup> to 0.83 N/mm<sup>2</sup> (65 psi to 120 psi; 4.5 bar to 8 bar)
- Air supply to be clean and free from oil with a maximum of 25% humidity

## MarSurf DR-1

Deck face measurement fixture



### Description

The **MarSurf DR-1** is designed for stable surface finish measurement on flat surfaces without the need for positional adjustment of the pick-up. Equipment with a magnetic base, the Marsurf DR-1 is ideal when measuring overhead or non-horizontal surfaces.

### Features

- Wide range of application
- Magnetic base provides for non-level mounting on ferrous surfaces
- The fixture can be used with M1 or M2 units

## Pick-ups for Mobile Roughness Measuring Instruments

### Pick-ups for multiple measuring tasks for the use with PFM/PFM 2

The pick-ups of type N are characterized by special construction features:

- Stylus tip geometry as per EN ISO 3274, standard  $2\ \mu\text{m}/90^\circ$  ( $80\ \mu\text{in}/90^\circ$ )
- Measuring force of approx. 0.7 mN (1.95 mofz) (as per EN ISO 3274)
- Reliable inductive converter
- Rugged, rigid housing
- Self-aligning, elastic bearings
- Reliable plug and socket connections

### The standard NHT 6 pick-up

for example, adapts to various surfaces to be traced due to the special design of its tracing arm and skid. Further pick-ups such as the NHT 11 are suited for recessed measuring points and grooves.



### NHT 6-100 pick-up

Type  
Skid radius

Contact point  
Measuring range  
Specification

### Order No. 6111501

single-skid pick-up with spherical skid  
25 mm (.984 in) in traversing direction,  
2.9 mm (.114 in) at right angles  
0.8 mm (.0315 in) in front of the stylus  
100  $\mu\text{m}$  (.00394 in)  
for plane surfaces, bores with a dia. larger than 6 mm, (.236 in) and a max. depth of 17 mm (.669 in), grooves with a width larger than 3 mm (.118 in);  
min. workpiece length = traversing length + 1 mm (.0394 in)

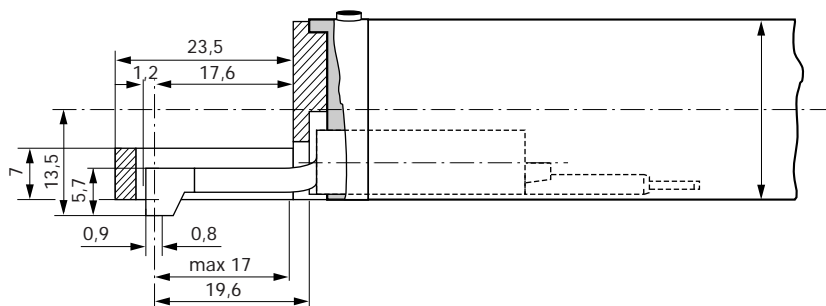

### NHT 6-150 pick-up

Type  
Skid radius

Contact point  
Measuring range  
Specification

### Order No. 6111504

single-skid pick-up with spherical skid  
25 mm (.984 in) in traversing direction,  
2.9 mm (.114 in) at right angles  
0.8 mm (.0315 in) in front of the stylus  
150  $\mu\text{m}$  (.00591 in)  
for plane surfaces, bores with a dia. larger than 6 mm (.236 in) and a max. depth of 17 mm (.669 in), grooves with a width larger than 3 mm (.118 in);  
min. workpiece length = traversing length + 1 mm (.0394 in)

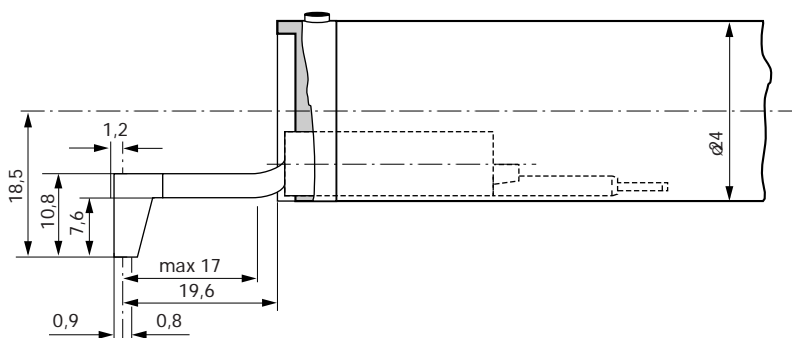

### NHT 11-100 pick-up

Type  
Skid radius

Contact point  
Measuring range  
Specification

### Order No. 6111505

single-skid pick-up with spherical skid  
25 mm (.984 in) in traversing direction,  
2.9 mm (.114 in) at right angles  
0.8 mm (.0315 in) in front of the stylus  
100  $\mu\text{m}$  (.00394 in)  
for plane surfaces, bores with a dia. larger than 11 mm (.433 in) and a max. depth of 14 mm (.551 in), grooves with a width larger than 2.5 mm (.0984 in) and a max. depth of 7.5 mm (.295 in)

**NHT pick-up extension (80 mm/3.15 in), Order No. 6850530** (for pick-ups of the "N-series")

## Pick-ups for Mobile Roughness Measuring Instruments

### NHTR-100 pick-up Order No. 6111508

Single-skid pick-up with lateral, spherical skid, radius 0.3 mm in traversing direction, stylus radius 5  $\mu\text{m}$  (200  $\mu\text{in}$ ), 90° suitable to measure inner radii in circumferential direction with a diameter larger than 12 mm (.472 in) (without figure).

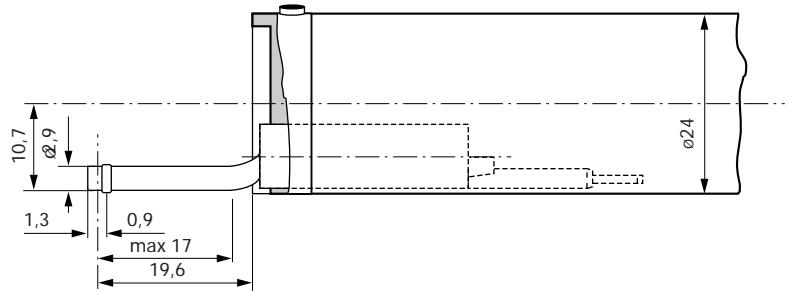

### NHT 3-100 pick-up

Type  
Skid radius

Contact point  
Measuring range  
Specification

### Order No. 6111502

single-skid pick-up with spherical skid  
25 mm (.984 in) in traversing direction,  
1.45 mm (.0571 in) at right angles  
0.9 mm (.0354 in) in front of the stylus  
100  $\mu\text{m}$  (.00394 in)  
for bores with a dia. larger than 3 mm (.118 in) and a max.  
depth of 17 mm (.669 in);  
min. workpiece length = traversing length + 1 mm (.0394 in)



### The NHTF 0.5 for gear tooth flanks

enables roughness measurements even at  
hardly accessible points.

### NHTF 0.5-100 pick-up

Type  
Skid radius

Contact point  
Measuring range  
Specification

### Order No. 6111503

single-skid pick-up with spherical skid  
25 mm (.984 in) in traversing direction,  
1.45 mm (.0571 in) at right angles  
0.6 mm (.0236 in) beside the stylus  
100  $\mu\text{m}$  (.00394 in)  
e.g. for gear tooth flanks with a modulus larger than 0.8

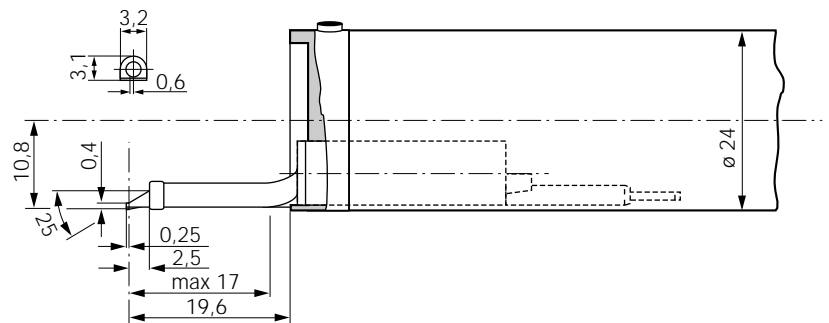

## Drive Units for Mobile Roughness Measuring Instruments

PFM drive unit



PFM 2 drive unit



### Description

The **PFM** drive unit can be connected to the Perthometers M1 and M2. It forms part of the Perthometer sets.

The drive unit can be used with the well-proved NHT skidded pick-ups.

For special measuring tasks, e.g. on crankshafts, the **PFM 2** drive unit with transverse tracing is available. This is connected as the standard **PFM** drive unit. If both drive units are used, the range of applications of the mobile Perthometers M1 and M2 is considerably raised.

### Technical Data

#### PFM drive unit

Traversing direction

Traversing lengths

as per DIN/ISO

as per EN ISO

Traversing speed

Dimensions

(w/o pick-up protection)

#### Order No. 6720907

longitudinal

set on the Perthometer

1.75 mm, 5.6 mm, 17.5 mm

(.07 in, .22 in, .7 in)

1 mm, 2 mm, 4 mm, 8 mm,

12 mm, 16 mm

(.0394 in, .0787 in, .157 in, .315 in,

.472 in, .63 in)

0.5 mm/s (.0197 in/s)

dia. 24 mm (.945 in),

L = 112 mm (4.41 in)

### Technical Data

#### PFM 2 drive unit

Traversing direction

transverse

Traversing lengths

set on the Perthometer

as per DIN/ISO

1.75 mm, 5.6 mm (.07 in, .22 in)

as per EN ISO 12085

1 mm, 2 mm, 4 mm

(.0394 in, .0787 in, .157 in)

Traversing speed

0.5 mm/s (.0197 in/s)

Dimensions

dia. 24 mm (.945 in), L = 112 mm (4.41 in)

(w/o pick-up protection)

#### PFM 2 set

consisting of:

**Order No. 6720909**

#### PFM 2 drive unit

Vee pick-up protection

Pick-up protection

Screwdriver

## Applications with PFM Drive Units

### Drive unit for shop floor applications



### Description

The robust **PFM drive unit** with its slim, cylindrical form is suited for measuring even complex workpieces. It is easily attached to mounting devices for stationary operation, while for manual operation, the hand-held support with its multiple contact surfaces offers various application possibilities. The optionally available **PFM 2** drive unit is suited for transverse tracing, e.g. between lateral shoulders on crankshafts.

Exchangeable front-mounting devices protect the pick-up and enable correct positioning on the workpiece. The vee pick-up protection, which is used when working without the hand-held support, is used for cylindrical workpieces.

Prismatic contact surfaces at the bottom and the end faces of the hand-held support also support the drive unit on cylindrical workpieces. For large workpieces, the drive unit is placed onto the surface to be traced.

For small workpieces, the hand-held support is placed upside down, thus serving as workholding device.

The multiple contact surfaces, the vertical adjusters and the possibility of shifting and turning the drive unit within the hand-held support, make the PFM a simple, but complete measuring station of so far unequaled flexibility.

Roughness measurements on workpieces which are still being manufactured require particular devices for solving the measuring task (e.g. transverse tracing on crankshafts or camshafts). With the Perthometer **M1** or **M2**, the **PFM 2** drive unit for transverse tracing, a shaft whipper and the vee pick-up protection, it is possible to perform such measurements on site and with high precision.

## Accessories



### PP vee-block Order No. 6710401

with four different prisms for mounting axis-symmetrical workpieces with diameters from 1 mm to 160 mm (.0394 in to 6.30 in). Dimensions (L x W x H) 100 mm x 80 mm x 40 mm (3.91 in x 3.15 in x 1.58 in). Weight 1.5 kg (3.31 lb). Including clamping springs for holding light workpieces in the prism.

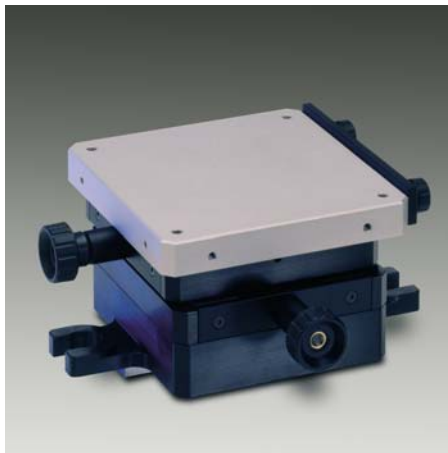

### XY table CT 120 Order No. 6710529

for mounting and aligning workpieces. Can be adjusted in two coordinates by 15 mm (.591 in). Table surface 120 mm x 120 mm (4.728 in x 4.728 in) with two brackets.

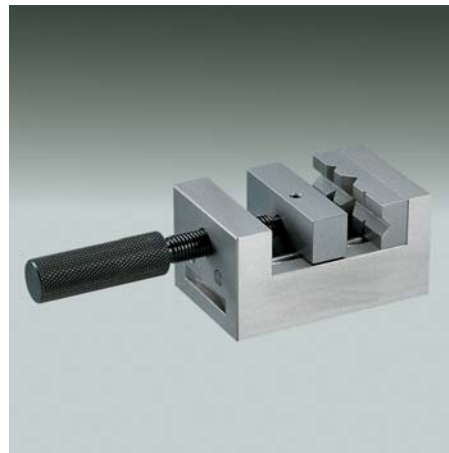

### PPS parallel vice Order No. 6710604

for mounting rectangular and cylindrical workpieces. Jaw width 70 mm (2.76 in), jaw height 25 mm (.984 in), span 40 mm (1.58 in), total height 58 mm (2.28 in). Weight 2 kg (4.41 lb).



### Shaft whippers for PFM 2 for diameters from 5 mm to 80 mm (100 mm) Order No. 6850738

Roughness measurements on workpieces which are still being manufactured require particular devices for solving the measuring task (e.g. transverse tracing on crankshafts or camshafts).

**Mahr or DKD calibration certificates are available on request.**



### PRN 10 roughness standard Order No. 6820420

with Mahr calibration certificate. Roughness standard with turned profil, chromed. Profile depth approx. 10  $\mu\text{m}$  (.394  $\mu\text{in}$ ). For checking the roughness measuring station.

### PGN 3 geometric standard Order No. 6820601

(without figure) Surface roughness standard with a sinusoidal groove profile. Profile depth approx. 3  $\mu\text{m}$  (120  $\mu\text{in}$ ), groove spacing approx. 0.12 mm (.00472 in). For checking the roughness measuring station.

## Accessories



### Measuring Stands

<b>Measuring stand ST-D</b>	<b>Order No. 6710803</b>
Height adjustment of PFM mounting device	0 mm to 300 mm (0 in to 11.81 in), by means of a handwheel
Triangular foot	
Dimensions (L x W x H)	175 mm x 190 mm x 385 mm (6.89 in x 7.48 in x 15.16 in)
Weight	approx. 3 kg (6.61 lb)
<b>Measuring stand ST-F</b>	<b>Order No. 2190832</b>
Height adjustment of PFM mounting device	0 mm to 300 mm (0 in to 11.81 in), by means of a handwheel
Table surface	400 mm x 250 mm (15.75 in x 9.84 in), granite
Dimensions (L x W x H)	400 mm x 250 mm x 422 mm (15.75 in x 9.84 in x 16.61 in)
Weight	approx. 24 kg (52.91 lb)
<b>Measuring stand ST-G</b>	<b>Order No. 6710807</b>
Granite plate with an 10 mm (.39 in) T-slot for mounting work-holding devices. Handwheel height adjustment for simply and exactly adjusting the drive unit to the required measuring height.	
Height adjustment of PFM mounting device	0 mm to 300 mm (0 in to 11.81 in), by means of a handwheel
Dimensions (L x W x H)	500 mm x 300 mm x 415 mm (19.69 in x 11.81 in x 16.34 in)
Weight	approx. 35 kg (77.16 lb)

### Measuring Stand Accessories

<b>Measuring stand accessories</b> (not included in the scope of delivery of the measuring stands):	
<b>PFM/PFM 2 mounting device</b>	<b>Order No. 6851304</b>
The drive unit can be swiveled and aligned in a range of $\pm 15^\circ$ by means of this mounting device.	
<b>M1/M2 support plate</b>	<b>Order No. 6851332</b>
with shoulder strap, for mobile use and for fixing the Perthometer to an ST-F, ST-D or ST-G measuring stand by means of the mounting device (Order No. 6851333).	
<b>M1/M2 mounting device</b>	<b>Order No. 6851333</b>
for fixing the Perthometer to an ST-F, ST-D or ST-G measuring stand by means of the support plate (Order No. 6851332).	

### Software

<b>MarSurf XR 20 evaluation software</b>	<b>Order No. 6299009</b>
Control of the M-unit via the RS 232 COM port Software access via a USB dongle, usable with Windows 2000 and Windows XP	

## The Perthometer Sets for Mobile Operation

**Perthometer M1 set** Order No. 6910134  
**Perthometer M1 set with 2008143 patch** Order No. 2190827

**Perthometer M2 set** Order No. 6910135  
**Perthometer M2 set with 2008143 patch** Order No. 2190828

The Perthometers of the M series are delivered as a set in a handy carrying case. The instrument is thus safely packed for transport. The components included in the set can easily and quickly be assembled to form a complete measuring station.

### Scope of delivery

The illustrated accessories form part of the Perthometer sets.

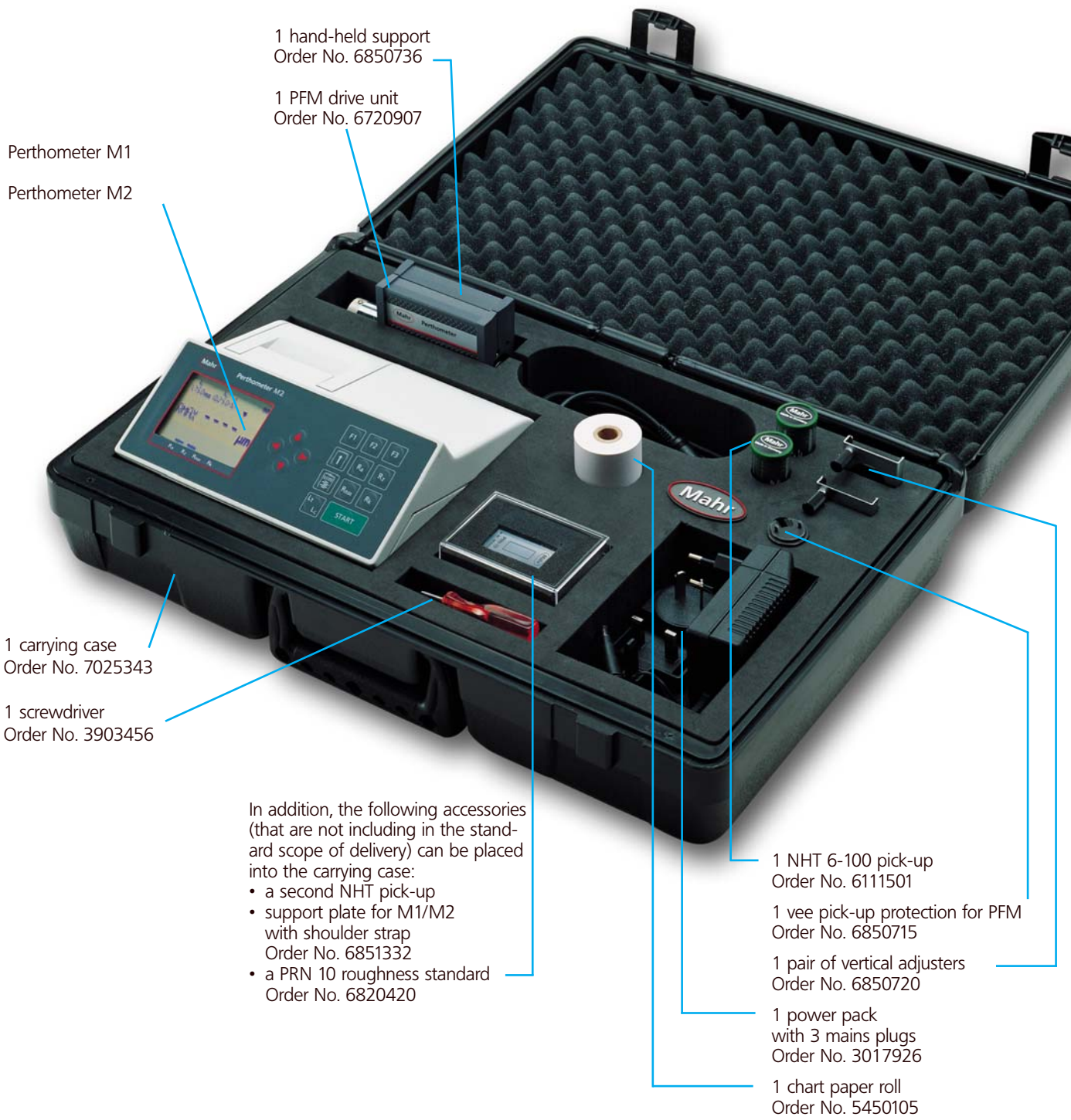

1 hand-held support  
Order No. 6850736

1 PFM drive unit  
Order No. 6720907

Perthometer M1

Perthometer M2

1 carrying case  
Order No. 7025343

1 screwdriver  
Order No. 3903456

In addition, the following accessories (that are not including in the standard scope of delivery) can be placed into the carrying case:

- a second NHT pick-up
- support plate for M1/M2 with shoulder strap  
Order No. 6851332
- a PRN 10 roughness standard  
Order No. 6820420

1 NHT 6-100 pick-up  
Order No. 6111501

1 vee pick-up protection for PFM  
Order No. 6850715

1 pair of vertical adjusters  
Order No. 6850720

1 power pack with 3 mains plugs  
Order No. 3017926

1 chart paper roll  
Order No. 5450105